



VRLA Battery **SPB 12-150**

Specifications	Nominal Voltage	12 V				
	Rated Capacity (25 °C)	20hr Rate (1,80V/cell)	10hr Rate (1,80V/cell)	5hr Rate (1,70V/cell)	1hr Rate (1,60V/cell)	
		164 Ah	150 Ah	133,5 Ah	94,3 Ah	
	Dimensions (mm) & Weight (kg)	Length	Width	Height	Overall Height	Weight
		485mm	172mm	240mm	240mm	47 kg
	Number / Type of Terminals	2 / M8				

Technical Characteristics

Design Life at 20°C	10-12 years
Eurobat Classification	High Performance
Internal Resistance (Fully charged - 25°C)	3,7 mΩ
Short-circuit current	2700 A
Max Charging Current	45 A
Min safe end Discharge Voltage	1,60 V/cell
Self discharge per month at 20°C	3%
Recommended Charging Voltage at 20°C	Stand-by use (V/cell): 2,25 to 2,30 Cycle use (V/cell): 2,40 to 2,50
Container Material	ABS-UL94 HB
Electrolyte Type	Sulfuric Acid
Type of plates / Alloy	Flat plates / Lead-Calcium-Tin alloy
Type of Separator	Absorbant Glass Mat
Valve Type / Operational Pressure	Rubber / 1-3 psi (70-200 mbar)
Operating Temperature Range	-20 to + 50°C
Storage time at 20°C	9 months

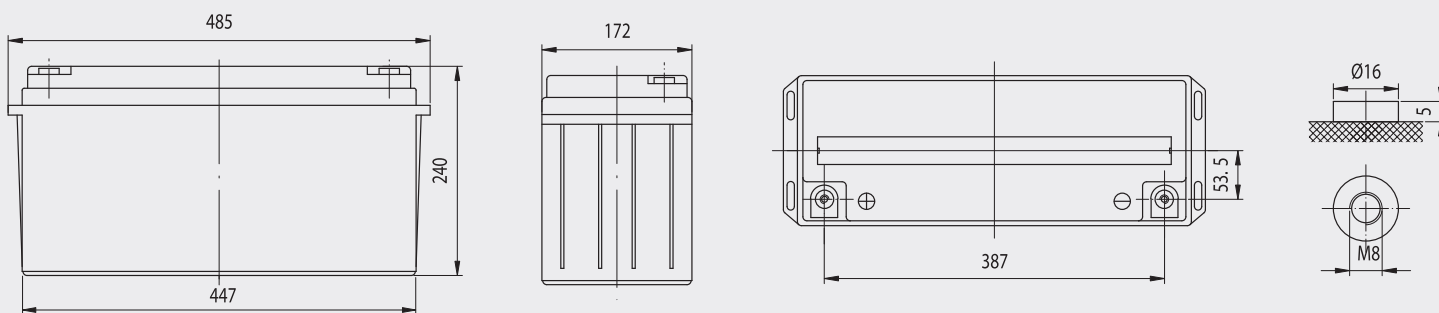

SYSTEMS SUNLIGHT S.A.

Headquarters

23rd Km. N.R. Athens - Lamia,
145 65 Agios Stefanos - Attica, Greece
Tel.: +30 210 624 5400,
Fax: +30 210 624 5409

Manufacturing Plant

Neo Olvio
67 200 Xanthi, Greece
Tel.: +30 25410 48100,
Fax: +30 25410 95446

SUNLIGHT
creating energy

www.sunlight.gr